



Color Variants

RF463307

Fully integrated, with ice and water dispenser

Niche width 61 cm, Niche height 213.4 cm

Included accessories

1 x connection set.

Optional accessories

RA450012

Activated charcoal filter for water filter system

Installation Accessories

RA422610

RA423140

RA425110

Handle bar, stainless steel, long

RA428810

RA460013

RA460020

Connecting element for vertically split appliance fronts (for a flush front)

RA464618

Ventilation grille stainless steel

RF463307

Vario freezer 400 series

Fully integrated, with ice and water dispenser

Niche width 61 cm, Niche height 213.4 cm

Left-hinged



Stainless steel interior with solid anthracite aluminium elements
Warm white and glare-free LED light spots

Opening assist for door with two options:

1. Push-to-open function for integration into handleless furniture front
 2. Pull-to-open function to facilitate opening the door using a handle
- The drawers in the fridge and freezer models are positioned at the same height.

With side-by-side installation, the glass shelves and door racks can be aligned on the same level

Material and aesthetics of interior as for RC model

- Glass shelves

Flat stainless steel inner door, full-length

Almost invisible rail system for shelves for flexible positioning

Illuminated dispenser for ice cubes, crushed ice and chilled water

Integrated ice maker with fixed inlet water connection

Proximity sensor for ice and water dispenser

TFT touch display

Total volume 304 litres

Handling

TFT touch display operation.

Clear text display.

Touch key operation for ice and water dispenser.

Features

Dynamic cold air distribution.

Automatic defrosting with defrost water evaporation.

Cushioned door closing system.

Rest mode certified by Star-K.

When rest mode is active, the appliance can only be opened using a handle.

Open-door and malfunction alarm.

Integrated WiFi module for digital services

(Home Connect).

The availability of the Home Connect functionality depends on the availability of the Home Connect Services in your country.

Home Connect Services are not available in every country – for further information please check:

www.home-connect.com

www.home-connect.com

Freezing

No-frost technology with fast freezing at -30 °C.

Temperature adjustable from -14 °C to -24 °C.

4-star freezer compartment.

Freezing capacity 18 kg /24 h.

Storage time after a malfunction 8 h.

4 safety glass shelves, 2 of which are individually height adjustable.

1 integrated shelf with satin-finished glass.

2 fully extendable drawers with transparent front.

Brilliant LED light spots with warm white, glare-free light (3500 K).

Ice and water dispenser

Warm white LED lighting.

Proximity sensor for automatic activation of light and touch keys for ice and water dispenser.

Characteristics

Energy Efficiency Class

F

Average annual energy consumption in kilowatt hour per year (kWh/a)

337

Sum of volume of frozen compartments

304

Airborne acoustical noise emissions

42

Airborne acoustical noise emission class

D

Thermometer freeze section

Light

Yes

Product category

Upright freezer

Construction type

Built-in

Door panel options

Not possible

Frost free system

Fridge and freezer

Height of the product

2125

Width of the appliance

603

Depth of the product

608

Required niche size for installation (HxWxD)

2134.0 x 610 x 610

Dimensions of the packed product (HxWxD)

2270 x 750 x 700

Net weight

156.1

Gross weight

171.3

Connection rating

300

Fuse protection

10

Frequency

50-60

Approval certificates

CE, VDE

Length of electrical supply cord

300

Door hinge

Left

Storage Period in Event of Power Failure (h)

8

Color / Material body

Defrost process

Warning signal / malfunction

Lockable door

No

Number of drawers/baskets (Stck)

2

Number of freezing flaps (Stck)

0

EAN code

4242006290825

Brand

Gaggenau

Product name / Commercial code

RF463307

Product category

Upright freezer

Integrated, with fixed inlet water connection.

Particle filter for water inlet, integrated in ventilation grille area.

Saturation indicator shown in TFT touch display.

Can be switched off.

Ice cube production approx. 1.4 kg/24 h.

Ice cubes and crushed ice.

Removable ice storage container with approx. 3.2 kg capacity.

Ice water supply approx. 1.5 litres.

Product rating

Energy efficiency class F at a range of energy efficiency classes from A to G.

Energy consumption 337 kWh/year.

Noise level 42 dB (A) re 1 pW.

Planning notes

Flat hinge.

Door opening angle of 115°, fixable at 90°.

For an installation with a door opening angle of 90°, the drawers have a restricted access.

Max. door panel weight 67 kg.

Shut-off valve for water connection must be planned next to the appliance and always be accessible.

If the water pressure exceeds 0.8 MPa (8 bar), connect pressure relief valve between water tap and hose set.

Connection

Total connected load 0.300 KW.

Connecting cable 3.0 m, pluggable.

Water inlet.

Supply hose 2.0 m with 3/4 " connection.

Water pressure 2 to 8 bar.

Consumption and connection features

created on 2022-03-10

Page 1

GAGGENAU

RF463307

Vario freezer 400 series

Fully integrated, with ice and water dispenser

Niche width 61 cm, Niche height 213.4 cm

Left-hinged

created on 2022-03-10
Page 2

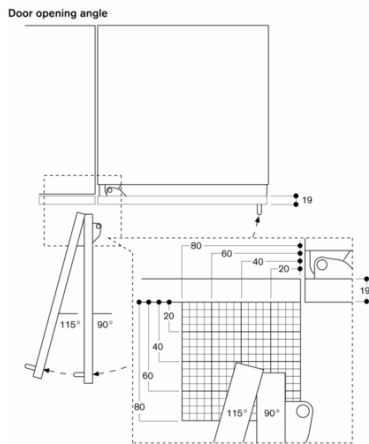
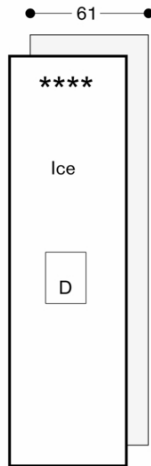

The hinge travel and resulting clearances from adjacent furniture units and handles can be found from the drawing while allowing for the thickness of the front panel. In the drawing, a furniture unit front panel thickness of 19 mm was assumed.

Base detail

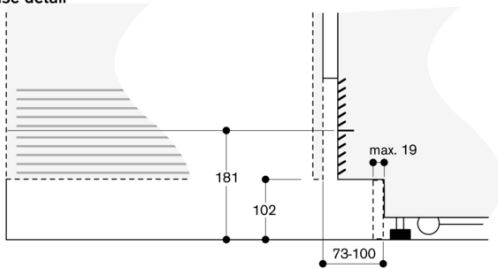

Based on the standard appliance height, the height of the plinth is 102 mm. Maximum plinth thickness 19 mm.

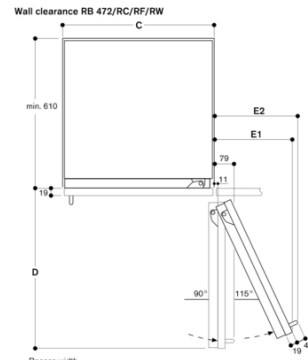

Recess width	C	D	E1	E2
457 mm	525 mm	235 mm	265 mm	
610 mm	677 mm	299 mm	330 mm	
762 mm	830 mm	364 mm	390 mm	
914 mm	980 mm	428 mm	460 mm	

In the drawing, a unit front thickness of 19 mm and a Gaggenau unit handle of 49 mm were taken as a basis.